

# Procedure for the Installation of Cassette Feeding Unit -X1

Follow the instructions described below to install the cassette feeding unit -X1 to copier.

1	Components
---	------------

Open the package and make sure that the following components indicated in the figure below are included.

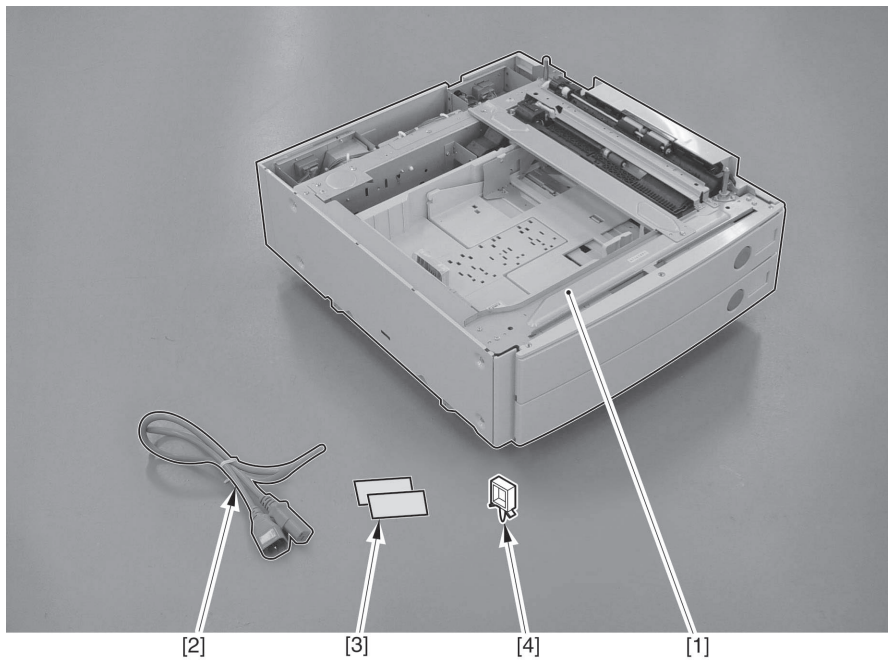

Fig.1-1

- [1] Cassette pedestal ..... 1 pc.
- [2] Power cable (for copier outlet) ..... 1 pc.
- [3] Cassette size label ..... 2 pc.
- [4] cable clamp ..... 1 pc.

## 2 Installation Procedure



Be sure to perform the following steps in sequence before starting the installation work on the host side:

1. Turn off the control panel power switch.
2. Turn off the main power switch.
3. Disconnect the power cable (for the outlet).

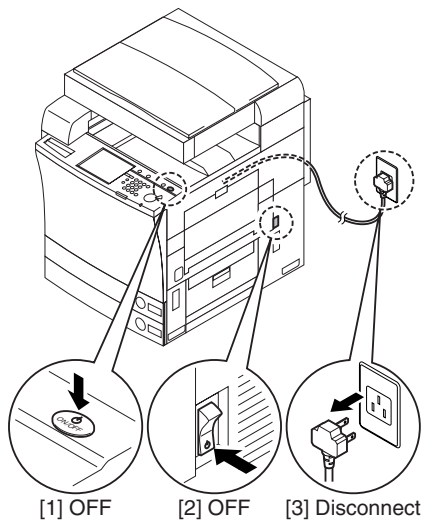

Fig. 2-1

When the optional cassette heater unit is to be installed, install it before installin the cassette pedestal (see the Installation Procedure F-IM-6116).

- 1) Remove all adhesive tape attached to the machine.
- 2) Draw out the top and bottom cassettes, and remove the lengths of tape used; then, remove the holding plate retainer [1].

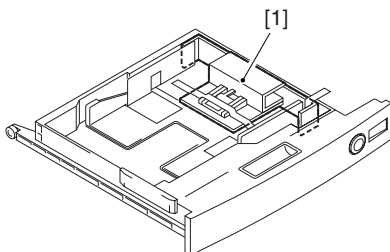

Fig. 2-2

- 3) Remove the cushioning material [1] from the bottom cassettes..

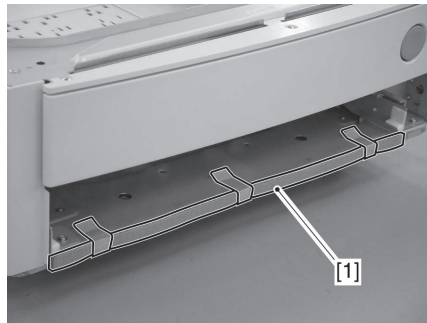

Fig. 2-3

- 4) Set both top and bottom cassettes.
- 5) Open the right cover [1] of the cassette pedestal.

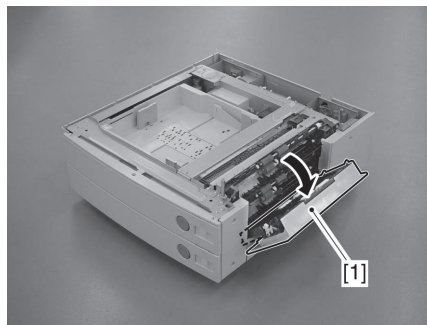

Fig. 2-4

- 6)



Copier weights 100 kg. When it is lifted up, make sure to do that by 4 people.



In order to put the copier main unit on top of the cassette pedestal, align the 2 positioning pins [1] on cassette pedestal with the holes in the bottom of the copier.

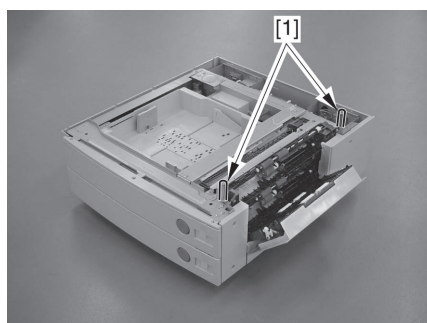

Fig. 2-5

- 7) Hold the 4 grips on the copier and place the copier on top of the cassette pedestal.
- 8) Remove the cover plate [1] on the lower right of the copier. (to be used later)

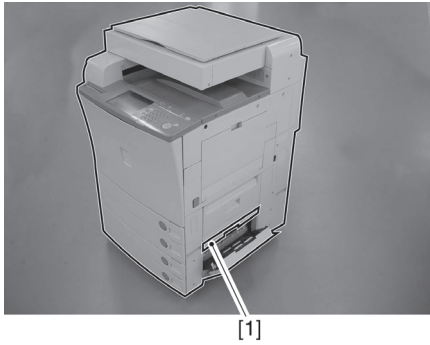

Fig. 2-6

- 9) Close the right cover on the cassette pedestal.
- 10) Remove the screw [1] found at the lower right of the cassette pedestal; then, using the screw, mount the face plate [2].



Fig. 2-7

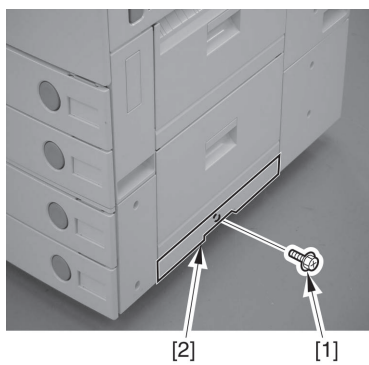

Fig. 2-8

- 11) Insert the connector [1] of the cassette pedestal to the copier.

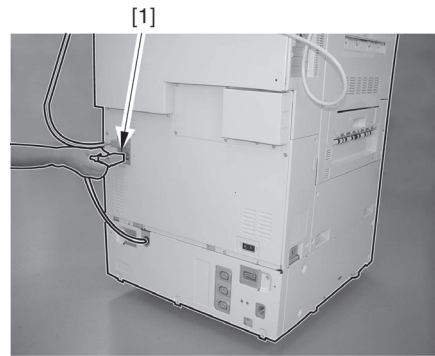

Fig. 2-9

- 12) Connect the cassette pedestal and the copier using the cable [1] that comes with the pedestal. (The cable is designed for connection to a copier outlet. Connect it to the middle of the 3 slots arranged vertically in the pedestal). Then, secure the pedestal using the cable clamp [2] that comes with the pedestal.

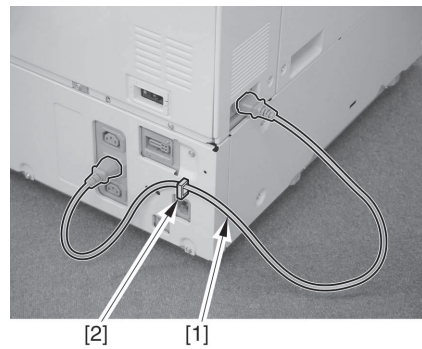

Fig. 2-10

- 13) Insert one end of the power cable (for plug outlet) [1] packed with the copier to the cassette pedestal, and insert the other end to the plug outlet.

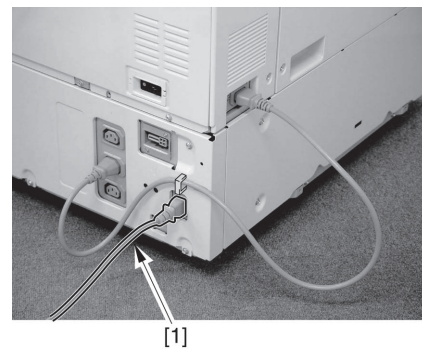

Fig. 2-11

14) Attach the cassette size label to the cassettes according to the paper size.



---

After the installation, rotate the 2 adjusters [1] at the bottom of the cassette pedestal so as to securely fix the cassette pedestal.

---

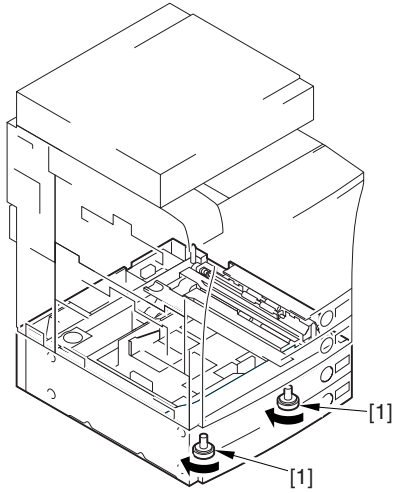

Fig. 2-12